



G-Force
YACHTS

Go over the edge
and discover
the X-factor of
G-Force Yachts

G-Force "REBEL"

- *The concept*
- *The design*
- *The building process*
- *The specifications*
- *Contact us*





G-Force

"REBEL"



G-Force
YACHTS

CONCEPT

The whole idea about the G-Force Rebel is to launch a high quality affordable dinghy which makes it possible to grow and develop racing tactics on the same hull.

The Rebel is available in 3 models. All dinghies with an enormous "fun factor" with spectacular performance under all circumstances.

The simple concept of the Rebel allows sailors to grow on the same boat. As base of all three models is the same hull..

The basic model "Fun" has a disc with several colours under the wind indicator. This coloured disc is calibrated with the mainsheet which is having the same colours. So when the wind indicator indicates for example yellow, the young sailor can ease out the sheet or pull the sheet in until the sheet is yellow and the trim is OK. An easy and effective way to learn how to sail. The more experienced sailor can upgrade his "Fun" with a bigger mainsail, a jib and stayed mast to the model "Fire" and when he / she is ready to go for true action the hull allows an easy adjustment of a genaker pole and a total genaker set to model "Radical" which can give the boat a speed of 15 knots at 17 knots true wind.

G-Force REBEL

- **EASY** – *easy to handle, with built in sense of details*
- **STRONG** – *design in harmony with material and construction*
- **STIFF** – *control even in extreme conditions*
- **FAST** – *modern design with speed in the genes*
- **LIGHT** – *unique build method – get more with less*
- **HANDY** – *easy and smooth handling – goes on the roof rack*
- **KNOWLEDGE** – *place it where it should be and fit it properly*
- **EXPERIENCE** – *what works is fun*
- **QUALITY** – *the best from the best, dock to loft*
- **COMPLETE** – *all included – ready n mounted from plant*
- **READY** – *rig - launch – sail*



REBEL - the concept

Up grade !

Fun



Fire



Radical



Design

The Rebel is a dinghy which is designed to perform under all circumstances and is built and designed by the G-Force Yachts principal: Strong, fast and responsive. The G-Force X-Treme 37 for example is the overall winner in the monohull class of the Cape to Bahia Ocean race 2006 and is currently used by the Shosholoza Team, the South African competitors in the America's Cup 2007.

So not just a "new kid on the block" but a serious contender amongst the competition. Not just "another dinghy" but a very well thought out concept, developed by G-Force Yachts in close co-operation with International dinghy sailors.



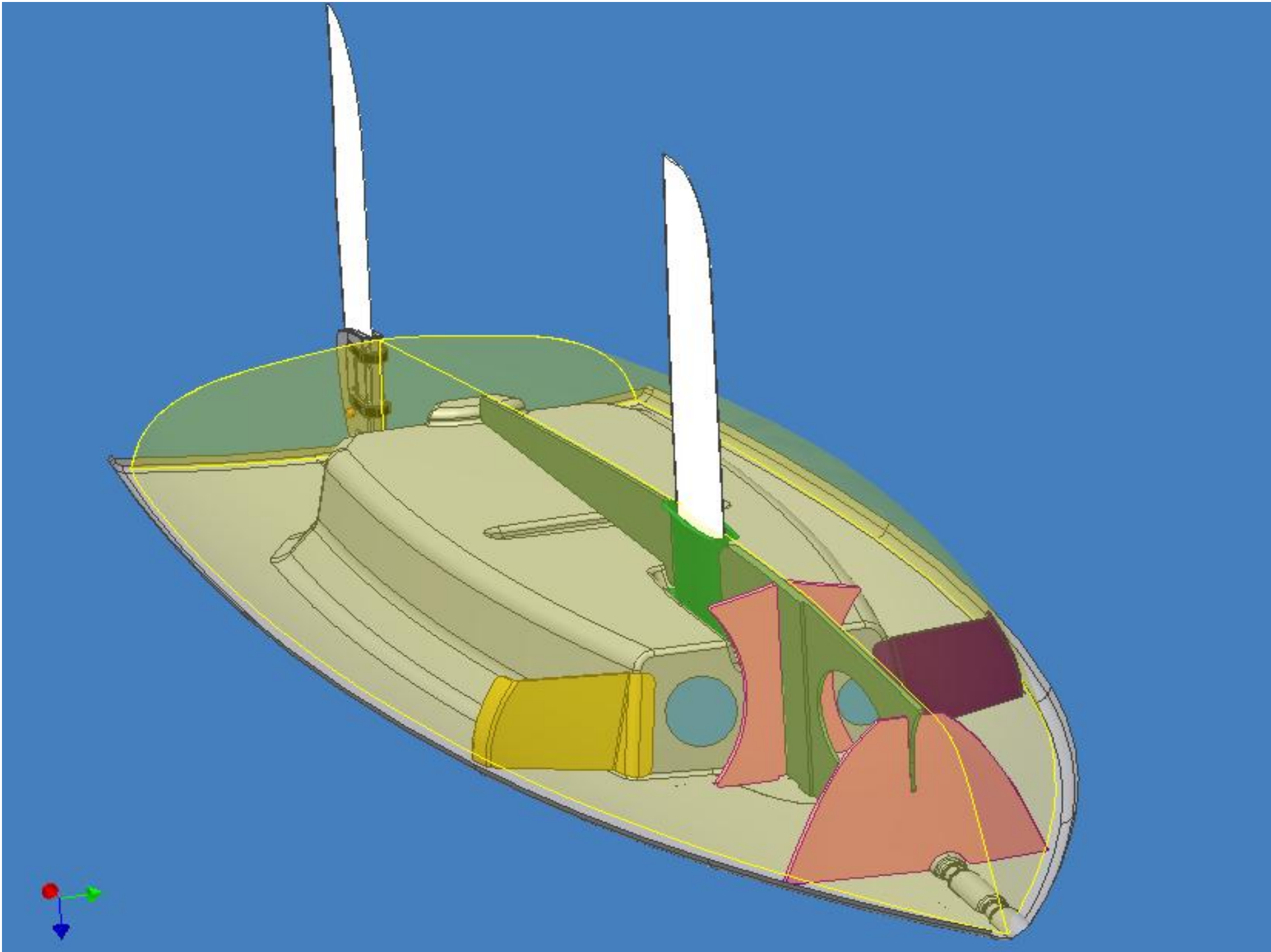

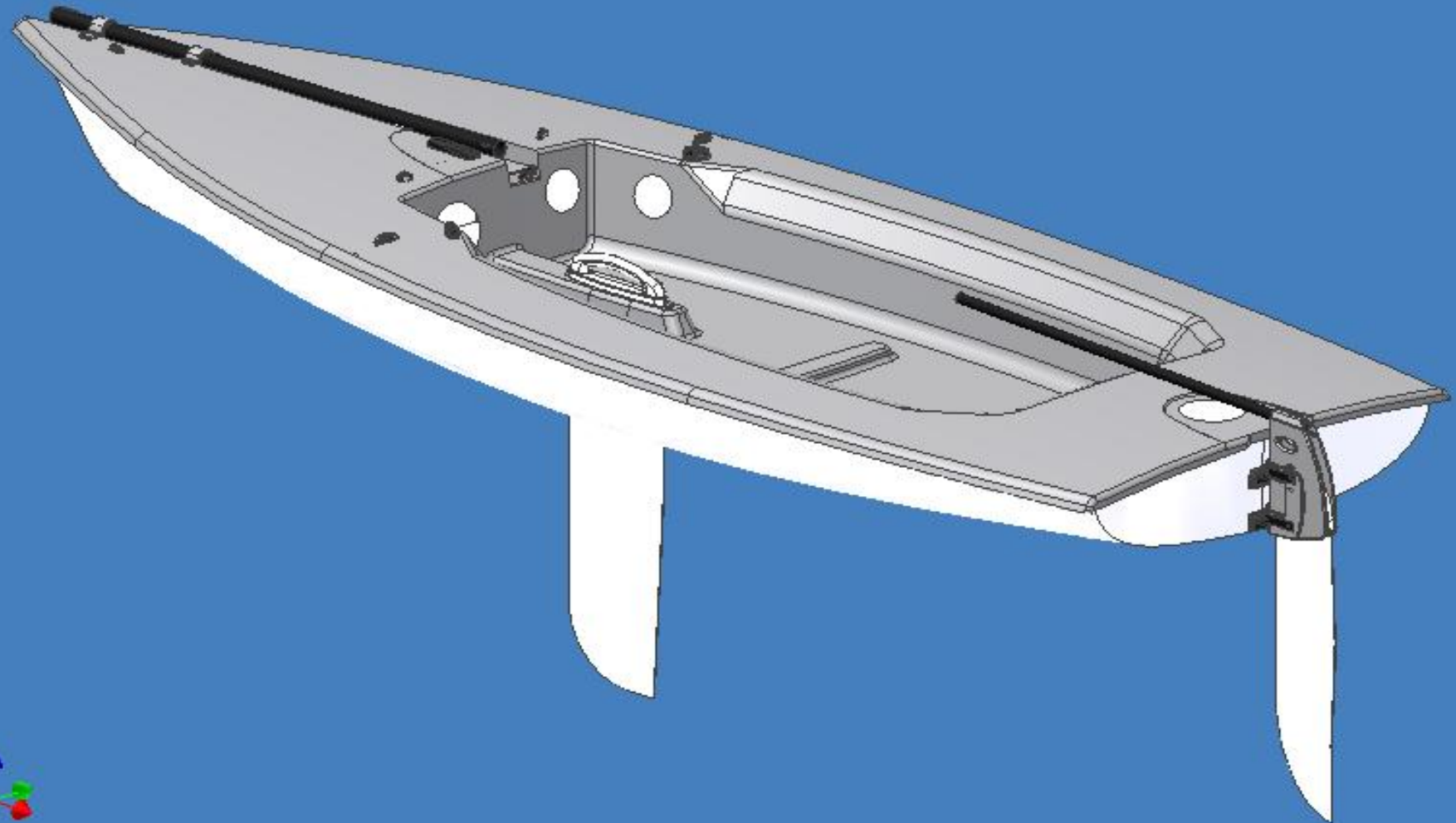

Building process

The name G-Force Rebel is not just chosen. This newly introduced dinghy sets in a rebellious way the new trend and goes beyond conventional dinghy concepts. Built with techniques which were never used before in this segment. The hull is made using resin infusion with a strong core of honeycomb and vinylester resin. The process is also used in the aviation industry and results in a hull weighing up to 20% less than polyester or PE boats but with a stronger and stiffer hull. The same process is used for the rudder and centerboard where carbon fibre is also used for additional strength. The result is a strong, fast boat with excellent handling characteristics at high speed.

Further the G-Force Rebel has a CE quality certificate and is the South African Boating Award 2006 winner in the category "non-powered trailerable craft".





Specifications

Type	Lenght	Weight hull	Sail area (mainsail + jib)	Gennaker area
« Fun »	4,32 m	78 kg	4,5 - 6 m2 (furling)	----
« Fire »	4,32 m	78 kg	8,65m2 + 2,42 m2	----
« Radical »	4,32 m	78 kg	8,65m2 + 2,42 m2	11,10 m2

Standard delivered with a set sails supplied by North Sails (dacron for model `Fun`, Pentex-Mylar for the `Fire` and `Radical`), mast by Proctor Selden and Ronstan hardware.



Contact us



Tel: + 46 (0) 70 344 98 65

+ 46 (0) 730 785 740

Mail: info@oceanspirit.se

web: www.oceanspirit.se

TROSA – SWEDEN



**G-Force
YACHTS**